

Installation Instructions

sport tuning

www.autotech.com

Part Number: 10.109.405K
Description: Vernier timing gear for Mk4 2.0L engines
Notes:

Our new vernier adjustment cam timing gear for the Mk4 2.0L engines consists of an anodized 6061 T6 aluminum sprocket and an alloy steel hub and cover plate. The proven vernier design allows for infinite incremental timing adjustment. It is possible to adjust the timing in 1.5° increments simply by aligning the holes in both the hub and sprocket at the desired position. There is no limit to the adjustment. A tool steel lockpin secures your timing position, held in place by the steel cover plate. Once set, this gear will not slip during use.

This type of gear is great for "degreeing" your camshaft to exact timing specs with no danger of slippage once assembled.

Tightening Torques:

- M12 socket head bolt to camshaft: 74 ft.lbs. (100Nm) << **Use Loctite® on bolt** >>
- Nut on timing belt tensionroller: 15 ft.lbs (20Nm)

Tips:

- To avoid timing errors, set the engine to TDC before removing the original sprocket, and install your new timing gear while it is set to its stock timing position (see illus below and next page). Cam timing may then be adjusted by turning the gear and selecting a lockpin location.
- The four (4) hash marks on either side of the TDC mark on the front perimeter of the gear are each 1.5 degrees apart.
- To install your new timing gear, follow factory removal and installation instructions. Timing instructions are attached for your reference.



< note the reference marks:
this sprocket is shown with
the lock pin in its stock (zero-
change) position.

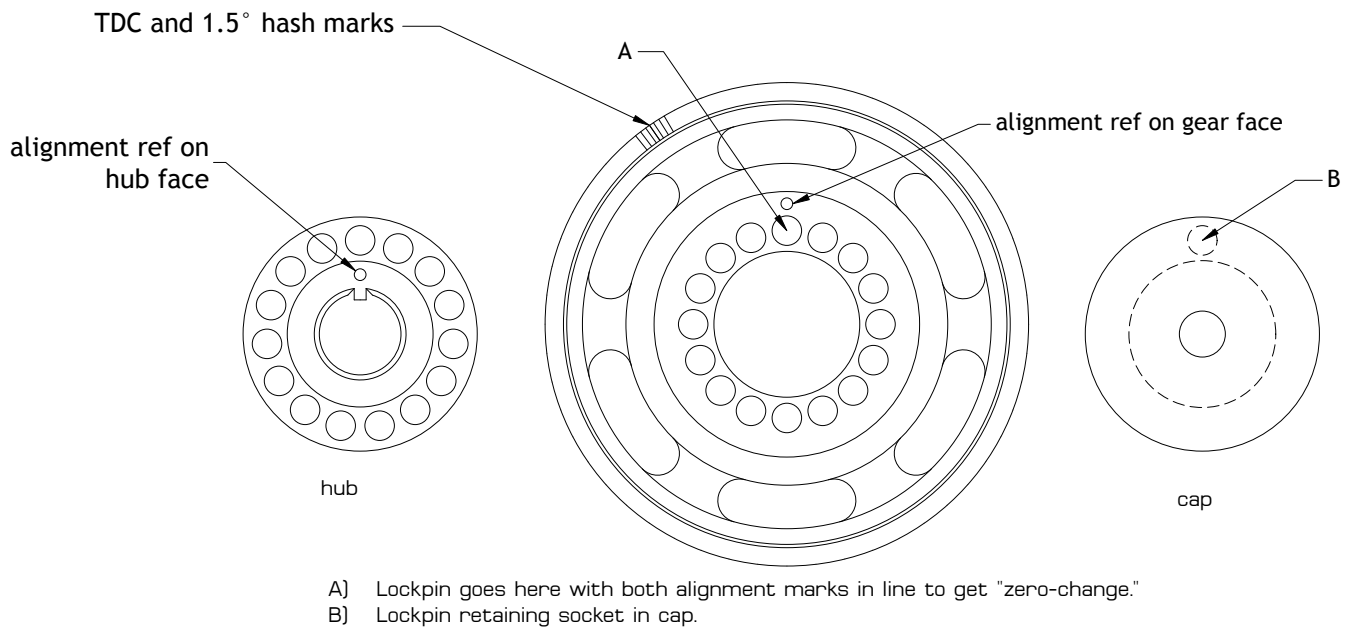

ENGINE TIMING NOTES:

To set timing, turn the camshaft timing sprocket (set like stock for now) until the TDC mark aligns with the mark on the valve cover or head as shown (Fig 3). The crankshaft should not have been moved, but you should double check that the crank is still at TDC.

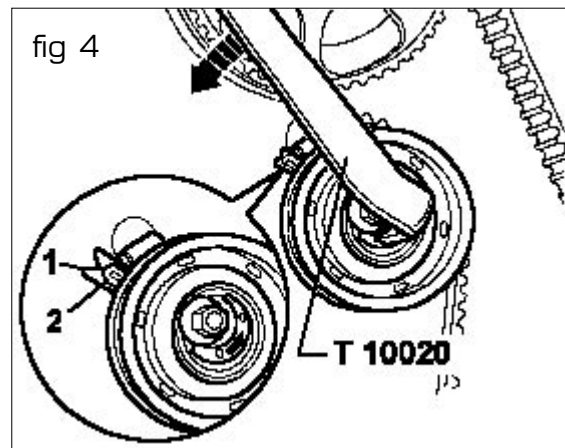
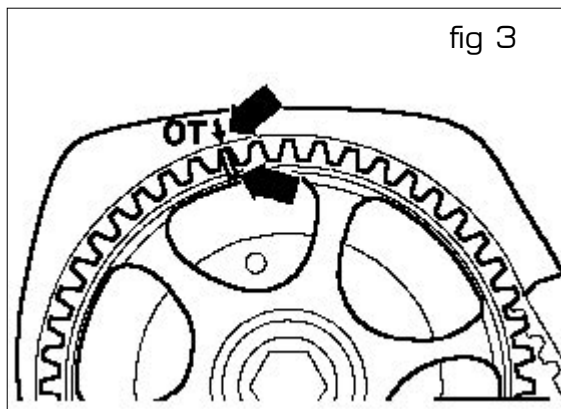

Note that depending on the camshaft used, the 2.0L engines may be "interference engines," meaning that the valves will hit the tops of the pistons if the engine goes out of time. Therefore, you cannot rotate the cams beyond the point where the valves hit the top of the piston on any one cylinder. Once TDC on both cams and crank are confirmed, place the timing belt on the camshaft timing sprocket and set the belt tension using the special tool (VW TOOL T10020) (fig 4). Torque the tensioner nut to spec (20 Nm/15 ft lb).