

A U T O T E C H

Installation Instructions

sport tuning

www.autotech.com

Part Number: 10.525.1628K

Description: rear swaybar installation for B5 chassis

Notes: These performance swaybars utilize Autotech's unique sliding endlink design that prevents binding of the bar (and preloading of the suspension) due to locational differences between the mounting points of the rear suspension and the swaybar itself.

TOOLS REQUIRED:

1. jackstands
2. electric drill and 10.5mm (27/64") bit
3. silicone lubricant
4. metric wrenches, 13 to 17mm
5. tape measure
6. moly grease

PARTS LIST:

1. rear swaybar
2. (4) poly bushings
3. (4) steel ring mounts
4. (2) 10mm rod ends
5. (6) 10mm hardened washers
6. (2) 10mm nylock nuts
7. (2) M10x100 shock bolts

Procedure:

1. Apply a generous amount of waterproof grease to the inside of the bushings, and some silicone spray along each of the bends on the swaybar.
2. Slide the two inboard mounts onto the swaybar and push them past both bends so that they end up on the middle, straight section of the swaybar. The inboard mounts will be installed on the axlebeam when they are as far apart from each other as possible without overlapping any of the bends on the bar. Measure, and take note of this distance. The distance from stud to stud on the inboard mounts should be approximately as follows:

B5 Chassis = 25 inches



3. Raise the rear of the car and place it on jackstands. Be sure that the car is in gear, the front wheels are chocked, and that it cannot roll.

(cont.)

4. Mark the axlebeam's crossmember for the hole locations using the distance you measured in step 1. The holes should be centered left-to-right (12.5 inches each side of the centerpoint). Use the tape to measure 1.5 inches up from the bottom edge of the crossmember.

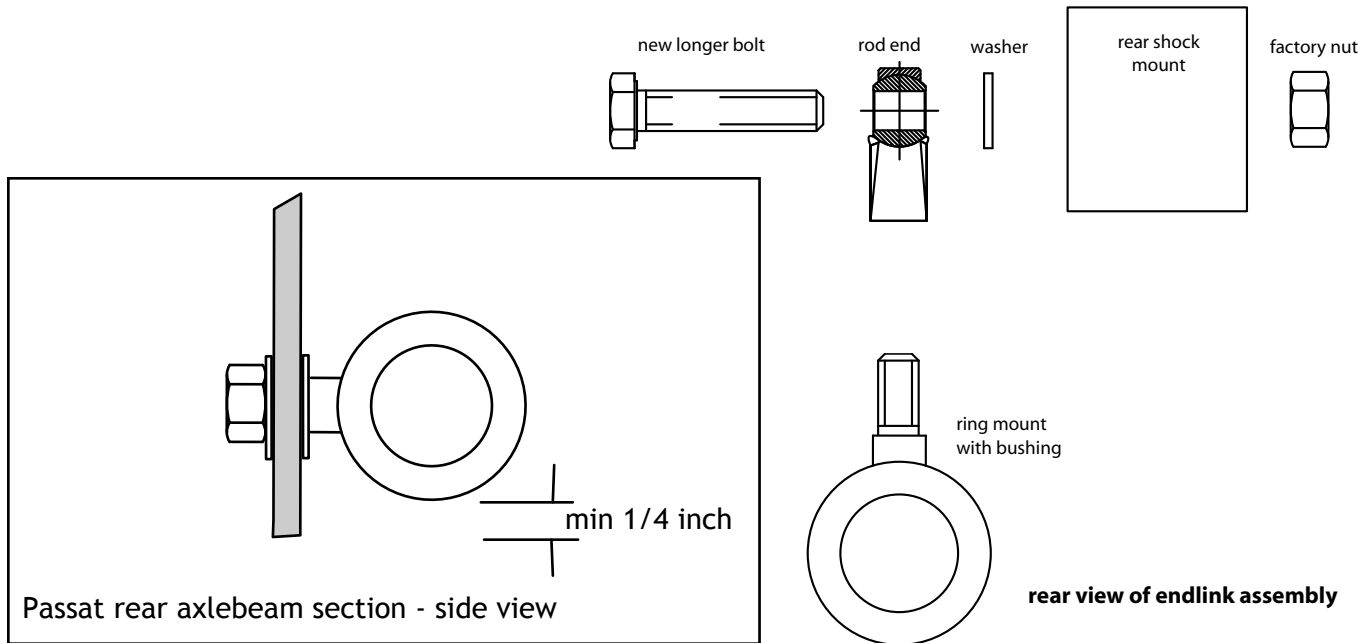

5. Drill the two 10.5mm (13/32" - 27/64") holes in the crossmember. It is a good idea to drill a pilot hole first so that the larger drill bit does not have to work so hard.
6. Mount the outboard rod ends on the car. The supplied longer shock bolts should go first through the rod end, next through the washer, then into the lower shock mount. Use the original nut to fasten the new bolt.
7. Thread the remaining two bar mounts into the rod ends.
8. Push each end of the swaybar into the end bushings. A small amount of silicone lubricant or a film of moly grease applied to the bar end and bushing eases the task.
9. Now swing the swaybar forward in order to push the inboard mounting studs through the drilled holes in the crossmember. Be sure to capture a washer on each side of the hole before attaching each inboard mount with the nylock nut.
10. Check all fasteners to be sure they are tightened properly.