

# A U T O T E C H

*sport tuning*

## Installation Instructions

www.autotech.com

**Part Number:** 10.525.1128K

**Description:** Non-Adjustable rear swaybar installation for A2 & A3 chassis

**Notes:** These performance swaybars utilize Autotech's unique sliding endlink design that prevents binding of the bar (and preloading of the suspension) due to locational differences between the mounting points of the rear suspension and the swaybar itself.

### TOOLS REQUIRED:

1. jackstands
2. electric drill and 10.5mm (27/64") bit
3. silicone lubricant
4. metric wrenches, 13 to 17mm
5. tape measure
6. moly grease

### PARTS LIST:

1. rear swaybar
2. (4) poly bushings
3. (4) steel ring mounts
4. (2) 10mm rod ends
5. (6) 10mm hardened washers
6. (2) 10mm thin jam nuts (1128K only)
7. (2) 10mm nylock nuts
8. (2) M10x90 shock bolts

### Procedure:

1. Apply a generous amount of waterproof grease to the inside of the bushings, and some silicone spray along each of the bends on the swaybar.
2. Slide the two inboard mounts onto the swaybar and push them past both bends so that they end up on the middle, straight section of the swaybar. The inboard mounts will be installed on the axlebeam when they are as far apart from each other as possible without overlapping any of the bends on the bar. Measure, and take note of this distance. The distance from stud to stud on the inboard mounts should be approximately as follows:

A2/A3 Chassis 29 inches

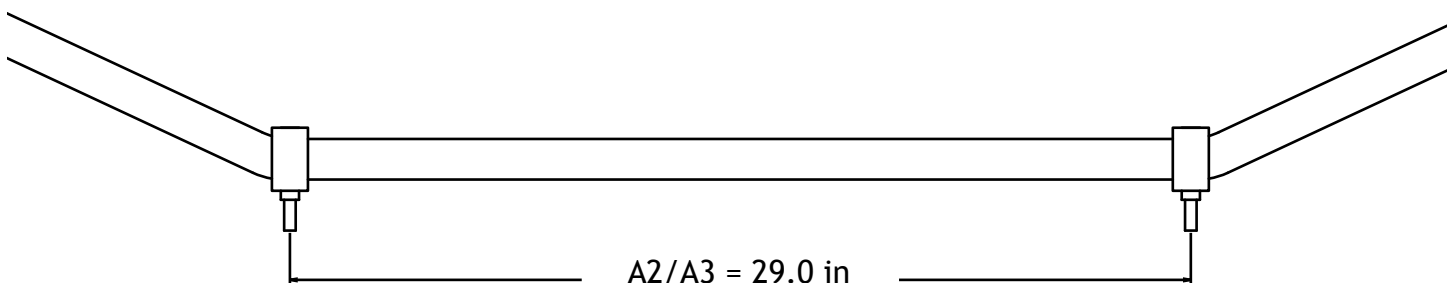

3. Raise the rear of the car and place it on jackstands. Be sure that the car is in gear, the front wheels are chocked, and that it cannot roll.

4. Mark the axlebeam's crossmember for the hole locations using the distance you measured in step 1. The holes should be centered left-to-right. Use the tape to measure 1.5 inches up from the leading edge of the crossmember. The holes should end up just below the center on the lower angled face of the beam.
5. Drill the two 10.5mm (13/32" - 27/64") holes in the crossmember. It is a good idea to drill a pilot hole first so that the larger drill bit does not have to work so hard.

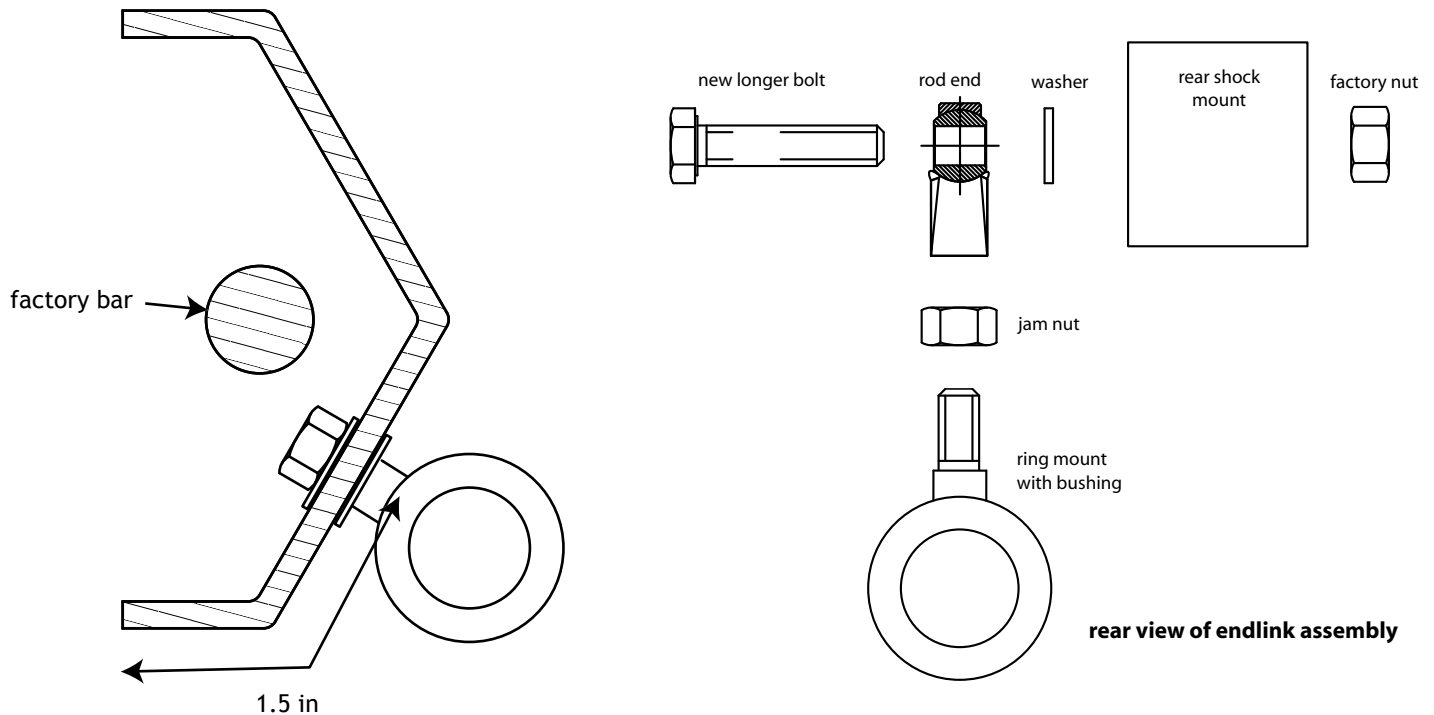

rear axlebeam section - side view

6. Thread the remaining two ring mounts (on A2/A3: with their jam nuts) into the rod ends. Do not tighten them as yet.
7. Push each end of the swaybar into the end bushings. A small amount of silicone lubricant or a film of moly grease applied to the bar end and bushing eases the task.
8. Now swing the swaybar forward in order to push the inboard mounting studs through the drilled holes in the crossmember. Be sure to capture a washer on each side of the hole before attaching each inboard mount with the nylock nut.
- 9t. Go back and tighten the jam nuts against the rod ends (A2/A3 only). Once that is done, recheck all fasteners to be sure they are tightened properly.